

Section A - Frame Assembly

| | | | |
|-----|---|------|-------------------------------------|
| 2. | Wrench - 7/16" Forged Steel - 2 (2000 only) | 76. | Screw 3/8" - 16 x 1/2" - set - 2 |
| 13. | Screw - 5/16" x 1/4" - set - 1 | 83. | Screw 5/16" - 18 x 3/4" - set - 2 |
| 23. | Key - 5/32" Allen - 1 | 96. | Pin - Cotter 3/32" x 3/4" - 1 |
| 24. | Pin - Motor Release - 2 | 101. | Pin - 1 |
| 36. | Key - 1/4" - Allen - 1 | 105. | Screw - 5/16" - 18 x 3/8" Thumb - 2 |
| 53. | Shaft - Fulcrum - 2 | 214. | Frame - 1 |
| 73. | Cover - Clean Out - 1 | 261. | Pan - Dust - 1 |

Section B - Fan Assembly

| | | | |
|-------|---|------|---|
| 55. | Bearing - Ball 6202 2RS1 - 3 | 117. | Washer - Flat #10 - 1 |
| 61. | Washer - Shakeproof - 2 | 121. | Screw - #8 - 32 x 1/2" FH. Machined - 3 |
| 64. | Nut - 3/8" - 24 Hex Jam - 1 | 138. | Washer - #1120 Shakeproof - 1 |
| 104. | Screw - 1/4" - 20 x 5/8" Soc. Cap - 4 | 141. | Shaft - Fan - 1 |
| 107. | Nut 1/2" - 20 x 3/16" Hex Jam Special - 2 | 142. | Arm - Idler - 1 |
| 108. | Fan - Vacuum - 1 | 143. | Spacer - Idler - 1 |
| 109. | Key - 1/8" x 1/2" Woodruff - 2 | 144. | Pulley - Idler - 1 |
| 110. | Seal - Dust 19 x 35 x 7 - 1 | 145. | Shaft - Idler Pulley - 1 |
| 111. | Collar - Fan - 1 | 149. | Cover - Retaining - 1 |
| 112. | Housing - Fan - 1 | 152. | Pulley - Fan - 1 |
| 112C. | Housing - Fan Complete | 162. | Ring - Retaining - 2 |
| 113. | Spring - Idler Arm - 1 | 170. | Screw - 10-32 x 3/8" R.H. - 1 |

Section C - Housing - Drum

| | | | |
|------|----------------------------|------|---|
| 51. | Block Assembly - 1 | 253. | Washer - Lock - 2 |
| 127. | Nut 6 - 32 Lock - 2 | 256. | Bumper - Drum Front Cover - 1 |
| 201. | Housing - Drum 2000 - 1 | 258. | Screw - 6 - 32 x 5/8" R.H. - 2 |
| 202. | Handle - Lifting - 1 | 259. | Screw - 6 - 32 - 1" R.H. - 2 |
| 203. | Hinge - Torpedo - 2 | 260. | Screw - 10 - 32 - 3/4 FH. - 8 |
| 204. | Cover - Drum Front - 1 | 262. | Nut - 5/16" - 7/8 Hex. - 2 |
| 205. | Nut 10- 32 Hex Locking - 8 | 268. | Screw 1/4 - 20 x 3/4 Flat Soc. Cap - 2 |
| 206. | Cover - Drum Side - 1 | 269. | Bumper Screw 10 - 32 x 1 Steel Pan Phillips - 3 |
| 207. | Latch - 1 | 270. | Brass Rivet - SE8-4 - 3 |
| 208. | Pin - Spring 1/4" x 1" - 2 | 290. | Housing - Drum Omega - 1 |

Section D - Drum Assembly

| | | | |
|------|--------------------------------|------|-----------------------------|
| 28. | Bearing - Drum 6205-2RSH - 3 | 217. | Spacer - Bearing Short - 1 |
| 209. | Drum - 2000 Plus - 1 | 218. | Nut - L.H. 24 mm - 1.5 - 1 |
| 210. | Tighteners - Sandpaper - 2 | 219. | Housing - Drum Cylinder - 1 |
| 211. | Nut - R.H. 24 - 1.5 - 1 | 222. | Ring - Retainer - 1 |
| 212. | Shaft - Drum - 1 | 244. | Spacer - Drum Long - 1 |
| 213. | Pulley - Drum - 1 | 257. | Seal - Dust 35 x 52 x 7 - 1 |
| 215. | Key - Drum Pulley 6x6x20mm - 1 | 289. | Drum - Omega - 1 |
| 216. | Key - Drum 6 x 6 x 15mm - 1 | | |

Section E- Dust Pipe and Elbow Assembly

| | | | |
|-----|--------------------|------|---|
| 71. | Elbow - Swivel - 1 | 79. | Seal - Elbow - 2 |
| 72. | Pipe - Dust - 1 | 103. | Screw - 3/8" - 16 x 1-1/4" Soc. Cap - 1 |
| 75. | Bracket - Dust - 1 | 104. | Screw - 1/4" - 20 x 5/8" Soc. Cap - 4 |

Section F - Drive Belt and Cover

| | | | |
|------|--|------|------------------------|
| 86. | Screw 1/4 - 24 x 3/4 Flat Soc. Cap - 1 | 151. | Belt - Drum - 1 |
| 126. | Screw 8-32 x 1/2 Pan- 2 | 154. | Pin - 3/16 x 1 1/2 - 2 |
| 146. | Shaft - Guard Holder - 1 | 254. | Guard - Belt 2000 - 1 |
| 148. | Clip - Guard Holder - 1 | 288. | Guard - Belt Omega - 1 |
| 150. | Belt - Fan - 1 | | |

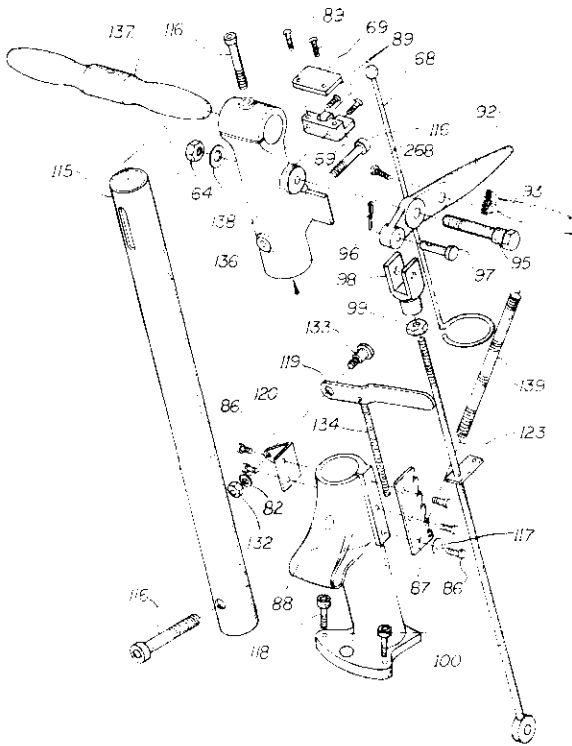

Section G

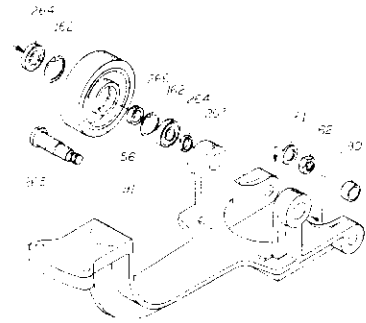

Section H

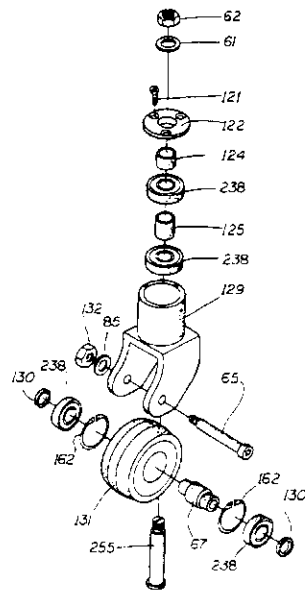
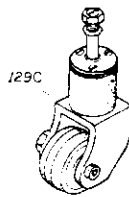

Section I

Section G - Control Lever and Spring Adjustments

| | | | |
|------|--|------|--|
| 64. | Nut - 3/8" - 24 Hex Jam - 1 | 115. | Tube - Handle - 1 |
| 68. | Rod - Cable Support - 1 | 116. | Screw - 3/8" - 16 x 2-1/2" Soc. Cap. - 3 |
| 69. | Bracket - Cable Support Assembly - 1 | 117. | Washer - Flat #10 - 1 |
| 82. | Washer - Shakeproof - 1 | 118. | Screw 5/16" - 18 x 1-1/4" Soc. Cap. - 2 |
| 86. | Screw - #10 - 24 x 1/2" Soc. Cap. H.D. - 5 | 119. | Lever - Pressure Control - 1 |
| 87. | Plate - Pressure Control Ratchet - 1 | 120. | Bracket - Pressure Lever - 1 |
| 88. | Chassis - Upper Truck - 1 | 123. | Plate - Spring Adjuster - 1 |
| 89. | Screw - 1/4" - 20 x 3/4" Soc. Cap. - 4 | 132. | Nut - 5/16" - 18 Hex - 1 |
| 92. | Handle - Control - 1 | 133. | Stud - 3/8" Shoulder Soc. Cap. - 1 |
| 93. | Handle Feathering - 1 | 134. | Spring - Pressure Control - 1 |
| 95. | Stud - Control Handle - 1 | 136. | Bracket - Handle - 1 |
| 96. | Pin - Cotter 3/32" x 3/4" - 1 | 137. | Handle - Grip |
| 97. | Pin - Clevis - 1 | 138. | Washer - Shakeproof #1120 - 12 |
| 98. | Yoke - Control Handle Rod - 1 | 139. | Spring - Buffing - 1 |
| 99. | Nut - 3/8" - 16 x 5/16" Hex - 1 | 268. | Screw - 1/4" - 20 x 3/4" - 1 |
| 100. | Rod - Control Handle - 1 | | |

Section H - Wheel Carriage Assembly

| | | | |
|-----|--------------------------------|------|-------------------------|
| 56. | Wheel - Front - 2 | 162. | Ring - Retaining - 4 |
| 61. | Washer - Shakeproof - 2 | 264. | Bearing - 6003 2RS - 4 |
| 62. | Nut - 1/2" - 20 Hex Jam - 2 | 265. | Shaft - Front Wheel - 2 |
| 90. | Bearing - Needle - M-12121 - 2 | 266. | Spacer - Wheel Long - 2 |
| 91. | Chassis - Lower Truck - 1 | 267. | Spacer - Wheel Short- 2 |

Section I - Rear Wheel Assembly

| | | | |
|------|--|-------|----------------------------|
| 61. | Washer - Shakeproof - 1 | 129. | Yoke - 1 |
| 62. | Nut - 1/2" - 20 Hex Jam - 1 | 129C. | Yoke Assembly |
| 65. | Shaft - Caster Wheel - 1 | 130. | Spacer - Caster Collar - 2 |
| 67. | Sleeve - Caster Wheel - 1 | 131. | Wheel - Caster - 1 |
| 85. | Washer - 7/8 Shakeproof - 1 | 132. | Nut - 5/16" - 18 Hex - 1 |
| 121. | Screw - #8 - 32 x 1/2" F.H. Machined - 3 | 162. | Ring - Retaining - 2 |
| 122. | Cover - Caster Yoke - 1 | 238. | Bearing - 6202 2RS - 4 |
| 124. | Collar - Short - 1 | 255. | Shaft - Swivel - 1 |
| 125. | Collar - Long - 1 | | |

SANDING BELT GUIDE MECHANISM SECTION J

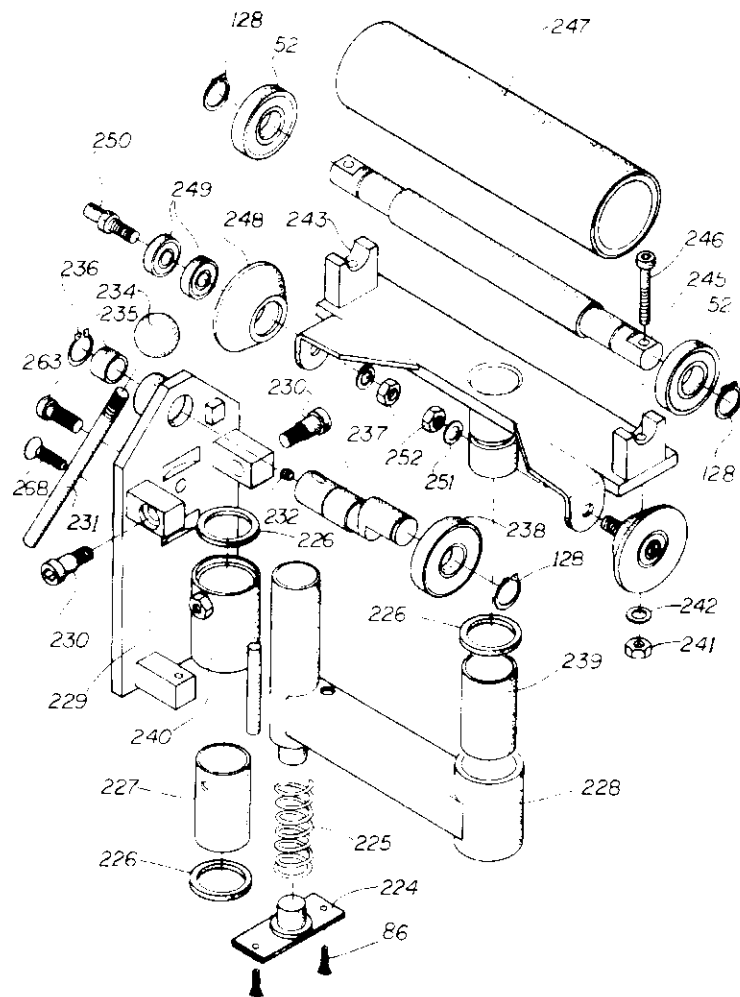

- | | | | |
|-------|---|-------|--|
| 52 | Bearing - Ball 6202 2RC/C3 - 2 | 238. | Bearing - 6202 2RS - 1 |
| 86. | Screw - 10 - 24 x 1/2" Soc. Cap. - 2 | 239. | Bushing Sleeve - 1 |
| 128. | Ring - Retaining 15mm - 3 | 240. | Housing - Adjusting Cylinder - 1(Incl. 226, 227) |
| 224. | Bracket - Tension Spring - 1 | 241. | Nut - 1/4" - 28 Hex. Jam - 2 |
| 225. | Spring - Tension - 1 | 242. | Washer - Lock 1/4" - 2 |
| 226. | Seal - Dust TCM0111VM - 3 | 243. | Bracket - Tension Roller - 1 |
| 227. | Bushing - Sleeve 1 | 243C. | Bracket - Upper Roller - Complete (Incl. 52, 128, 247C, 248C, 251, 252) |
| 228. | Arm - Tension Support - 1 | 245. | Shaft - Tension Roller - 1 |
| 228C. | Arm Assembly Complete. (Incl. 226, 227, 228, 239, 240) | 246. | Screw - 1/4" - 28 x 1 3/4" Soc. Cap - 2 |
| 229. | Plate - Support Mechanism - 1 | 247. | Roller - Tension - 1 |
| 229C. | Lower Support Mechanism - Complete (Incl. 86, 128, 224, 225, 228C, 229, 230, 231, 232, 234, 235, 236, 237, 240, 263, 268) | 247C. | Roller - Tension - Complete (Incl. 52, 128, 245, 246, 247) |
| 230. | Screw 5/16" x 3/8" Shoulder - 2 | 248. | Roller - Sandpaper Guide - 2 |
| 231. | Lever - Release - 1 | 248C. | Guide Roller - Sandpaper - Complete (Incl. 248, 249, 250) |
| 232. | Screw - Soc 1/4" x 1/4" - 1 | 249. | Bearing 607-2RS1 - 4 |
| 234. | Knob - Lever - 1 | 250. | Shaft - Sandpaper Guide Roller - 2 |
| 235. | Bearing - Needle SCE 1010 - 1 | 251. | Washer - Lock - 2 |
| 236. | Ring - Retaining 5/8" - 1 | 252. | Nut - 6mm Hex. Jam - 2 |
| 237. | Shaft - Roller Release Guide - 1 | 263. | Screw - 5/16" - 24 x 2" Soc. Cap. - 1 |
| | | 268. | Screw - 1/4" - 24 x 3/4" Flat Soc Cap - 4 |

04. P
08. F
09. C
10. S
11. B
12. H
12C. M
16. I
19. B
28. B
29. S
30. C
32. C
35. R
37. S
40. S
41. I

MOTOR ASSEMBLY SECTION K

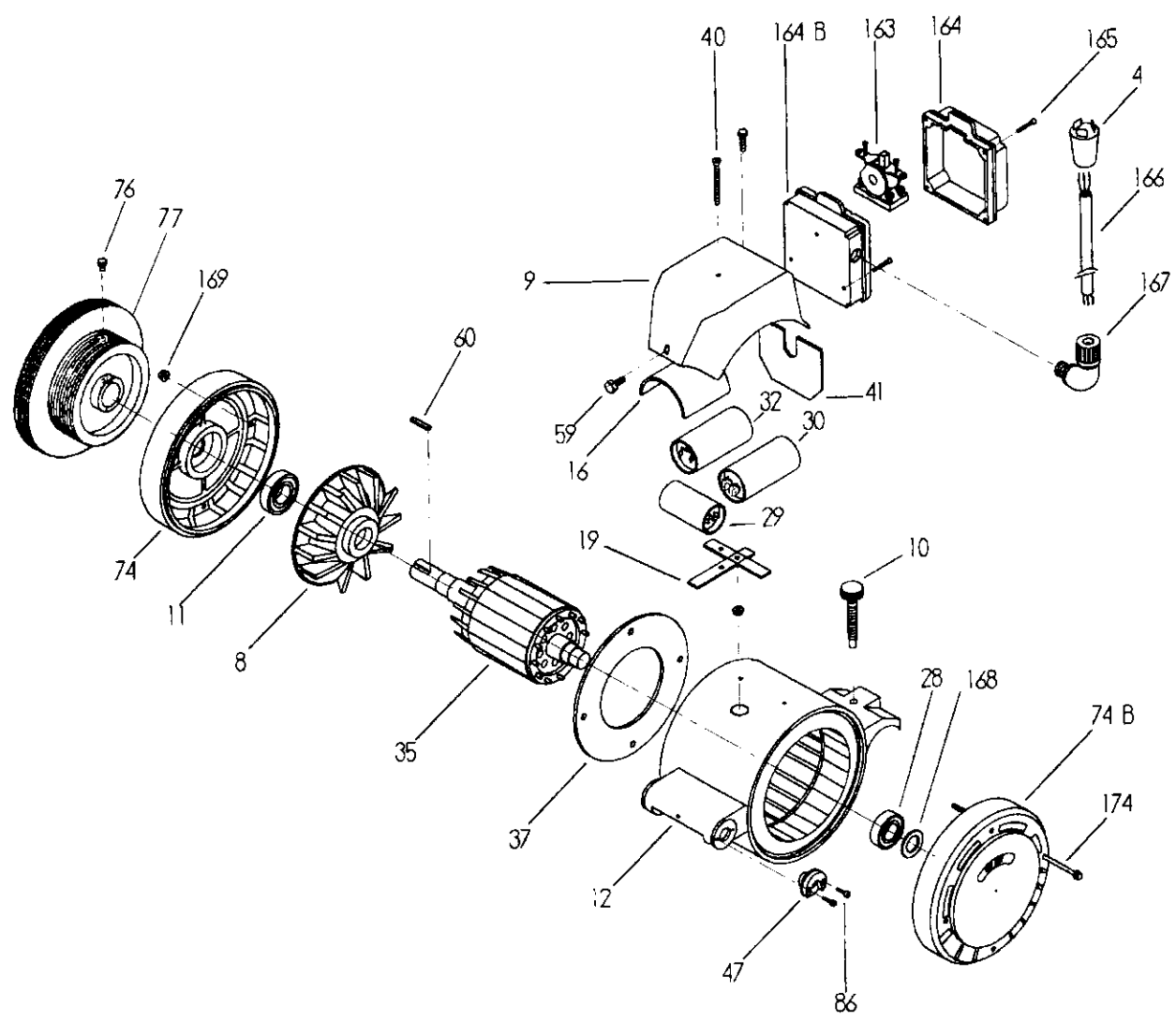

- | | | | |
|------|--------------------------------|-------|-------------------------------------|
| 04. | Plug - Male - 30Amp - 1 | 47. | Plate - Motor Release Pin Guide - 2 |
| 08. | Fan - Cooling - 1 | 59. | Cover - Bolt - 1 |
| 09. | Cover - Capacitor Assembly - 1 | 60. | Key - 1/4" x 1-1/2" - 1 |
| 10. | Screw - Motor Adjust - 1 | 74. | Bell - End Front - 1 |
| 11. | Bearing - 6206 2RS1/C3 - 1 | 74B. | Bell - End Back - 1 |
| 12. | Housing - Motor Assembly - 1 | 76. | Screw - Set 3/8 - 16 x 1/2 - 1 |
| 12C. | Motor Assembly Complete | 77. | Pulley - Motor - 1 |
| 16. | Insulator | 86. | Screw - #10 - 2 |
| 19. | Bracket - Capacitor - 1 | 163. | Switch - On/Off - 1 |
| 28. | Bearing - 6205 - 2RSH - 1 | 164. | Box - Switch Top - 1 |
| 29. | Switch - Sinterpac - 1 | 164B. | Box - Switch Bottom - 1 |
| 30. | Capacitor - Starting - 1 | 165. | Screw - 8/32 x 1" F.H. Machined - 4 |
| 32. | Capacitor - Running - 1 | 166. | Cord - Pig Tail - 1 |
| 35. | Rotor - Assembly - 1 | 167. | Retainer - Cord - 1 |
| 37. | Shield - Fan - 1 | 168. | Washer - Spring - 1 |
| 40. | Screw - | 169. | Nut - Flange - 1/4" - 20 - 3 |
| 41. | insulator | 174. | Bolt - Motor - 4 |

ELECTRICAL SECTION L

GALAXY MOTOR - 7 1/2 HP 60 Hz WIRING DIAGRAM 1/05

MODEL NO. 6506-200

WARNING!
DISCONNECT POWER SUPPLY
BEFORE SERVICING

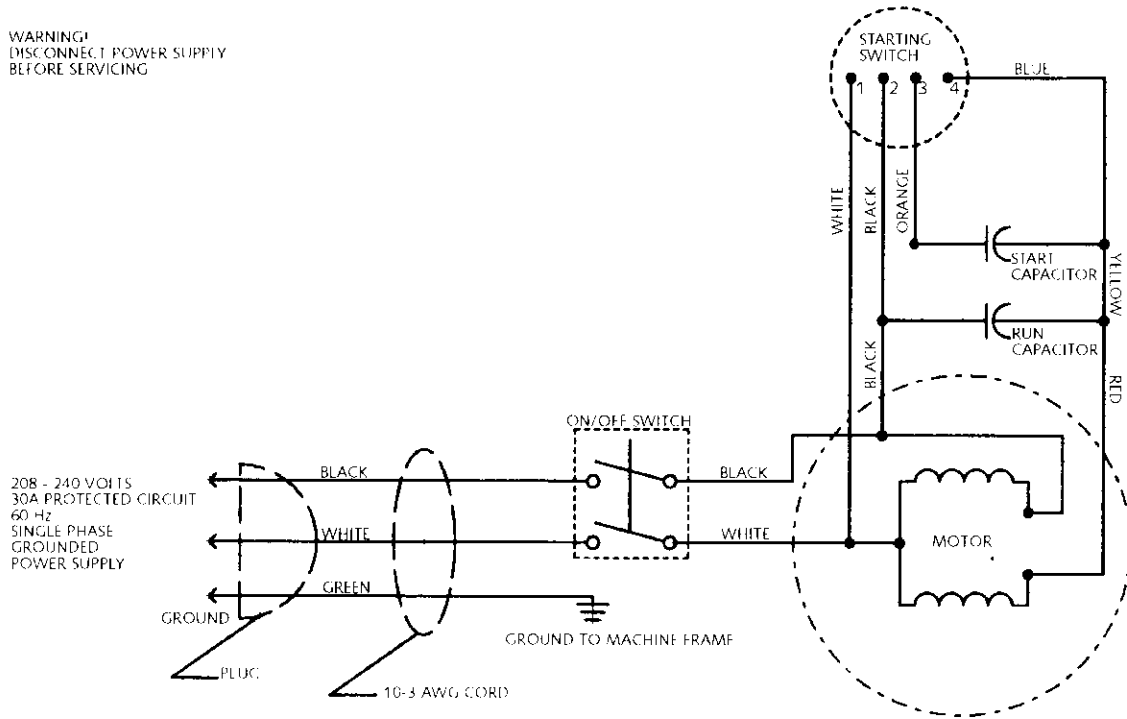

TECHNICAL 1-800-263-5667

- 29. Sinpac
- 30. Capacitor - Starting 218MF

- 32. Capacitor - Running 40MF - 50 MF
- 163. Switch - On/Off.

- 1.
- 1B.
- 3.
- 4.
- 5.